

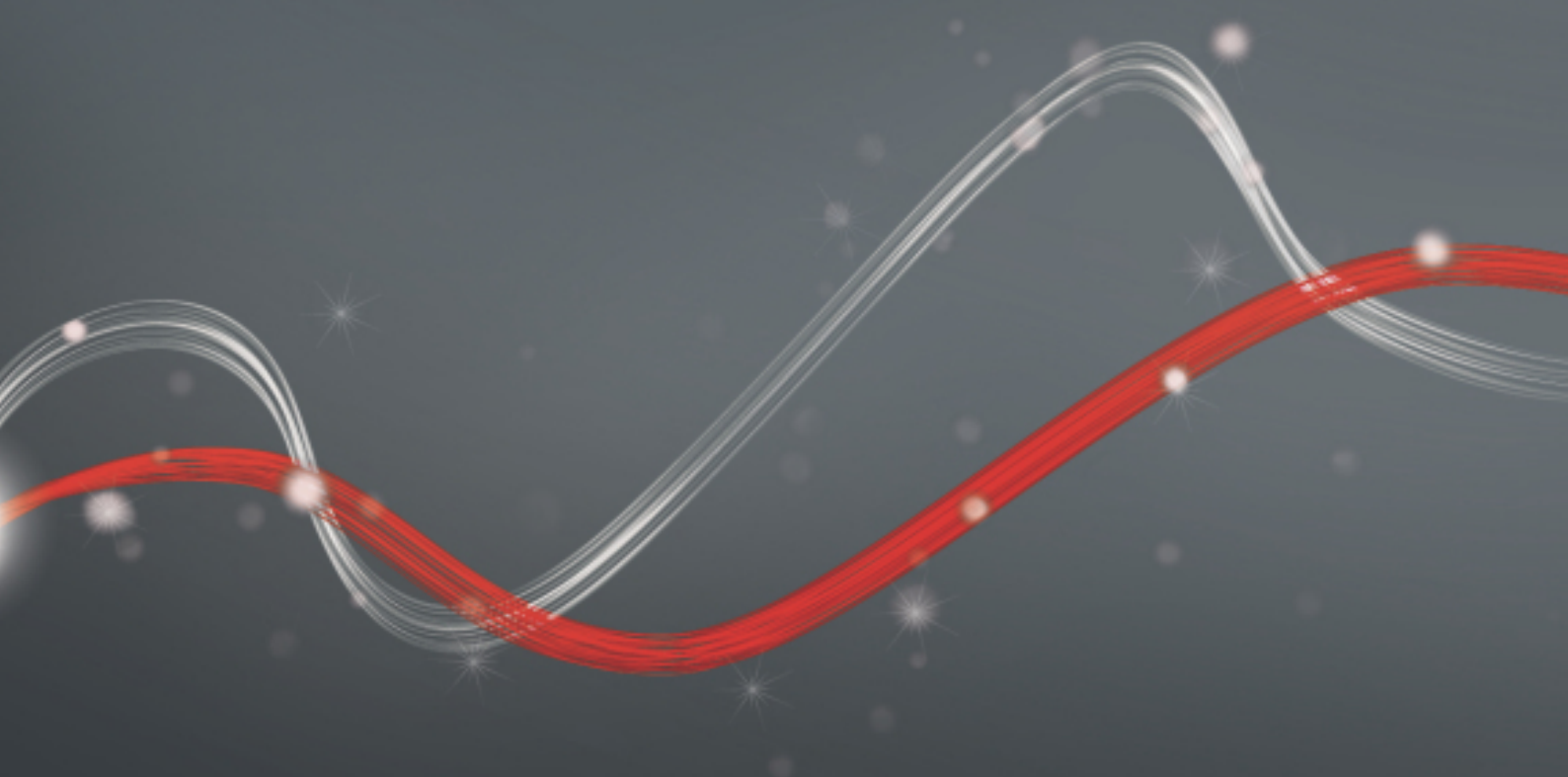

Be ahead



MICHELANGELO BT A



Product

PLUS

TECHNICAL FEATURES

ACCESSORIES

DISCOVER U-LINK

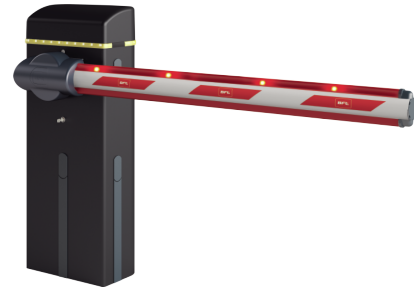

- ee link
- 24 V
- er ready
- U-Link

Empowered by
U-LINK

MICHELANGELO BT A

- 24 V
- ee link
- er ready
- U-Link

Code	Name	Description
P940076 00002	MICHELANGELO BT A 60 U	Barrier with 24 V power supply for useful passage up to 6 m and opening time 6 sec. Impact reaction via encoder. Control unit with ULink slot, display and receiver in head. RAL 7015 grey colour
P940077 00002	MICHELANGELO BT A 80 U	Barrier with 24 V power supply for useful passage up to 8 m and opening time 8 sec. Impact reaction via . Control unit with ULink slot, display and receiver in head. RAL 7015 grey colour

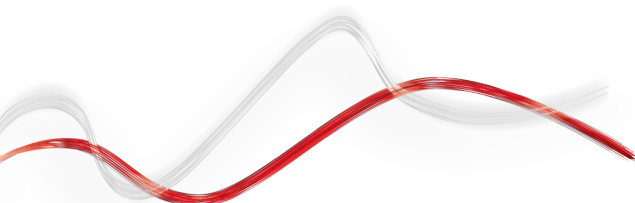

· Product

· **PLUS**

· TECHNICAL FEATURES

· ACCESSORIES

· **DISCOVER U-LINK**

PLUS



New control board Merak BM with U-Link connectivity slot, programming display and two-channel radio receiver incorporated. Mounted in the upper part of the barrier for an easier and convenient access.



IP54 protection level and new design.

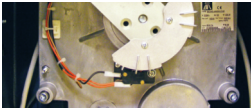

Limit switch system with electronic adjustment that speeds up installation and ensures maximum precision in movement.



Backup battery power supply system, installable on-board unit.

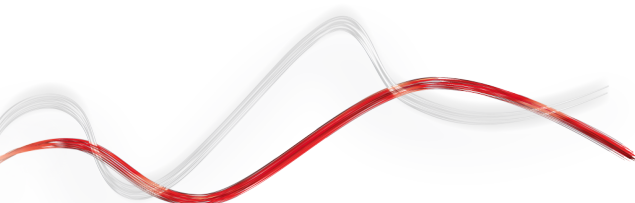

• Product

• PLUS

• **TECHNICAL FEATURES**

• ACCESSORIES

• DISCOVER U-LINK

	MICHELANGELO BT A 60 U	MICHELANGELO BT A 80 U
Useful passage	6 m	8 m
Opening or closing time	6 sec	8 sec
Control unit	MERAK BM	
Motor power supply	24 V	24 V
Type of limit switch	electronic	
Slowdown	adjustable	adjustable
Locking	mechanical	mechanical
Release	key	key
Frequency of use	intensive	intensive
Environmental conditions	from -20 (-40 with thermo) °C to 50 °C	
Protection rating	IP54	

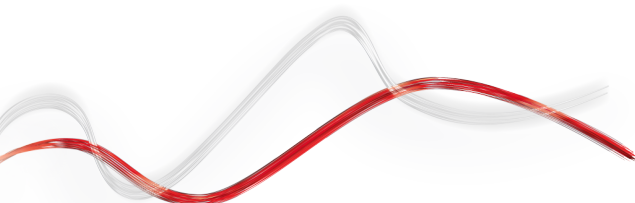
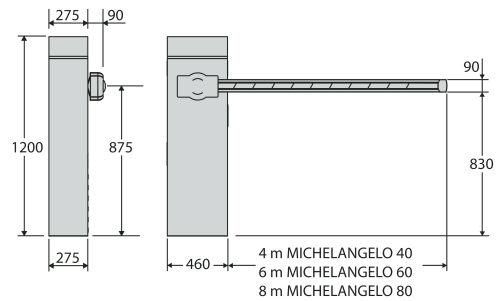









· Product

· PLUS

· TECHNICAL FEATURES

· **ACCESSORIES**

· DISCOVER U-LINK

	Code	Name	Description
	D730964	BM	adjustable base plate for mod. MICHELANGELO - BM
	N728022	AQ6	Complete 6 m rectangular boom for MICHELANGELO
	N728026	AT 704	Round boom \varnothing 70 mm, length 4.3 m. for clear spaces up to 4 m ATT 704
	N728030	AT 706	Round boom diam. 70 mm length 6.35 m for MICHELANGELO. for openings up to 6 m
	N728028	AT 502	Second part of telescopic round boom for MICHELANGELO, diam. 50 mm, length 2.6 m.
	N728027	AT 504	Second part of telescopic round boom for MICHELANGELO, diam. 50 mm, length 4.6 m.
	N999606	OMEGA AQ 6	Accessories pack for AQ 6 boom
	N999607	OMEGA AT 70	Accessories pack for AT 704/706
	P120028 00001	PCA N3	Top and bottom rubber cover profile for booms of 3 m max.
	P120028 00002	PCA N4	Top and bottom rubber cover profile for booms of 4 m max.
	P120028 00003	PCA N5	Top and bottom rubber cover profile for booms of 5 m max.
	P120028 00004	PCA N6	Top and bottom rubber cover profile for booms of 6 m max.
	P120028 00005	PCA N8	Top and bottom rubber cover profile for booms of 8 m max.
	P120006	MCL LAMPO KIT	Integrated flashing light. The MCL CARD KIT is needed for operation
	P120009	SCHEDA MCL KIT	Control board for KIT MCL LIGHT and KIT MCL LAMPO
	P120005 00001	MCL LIGHT KIT	Set of lights (6) for boom. To be used with (MCL) PCA 6, PCA 8. The MCL CARD KIT is necessary for operation
	D573003	SB	Aluminium skirt for road barrier booms. Price per linear metre (Calculate length of useful passage minus 40cm)
	P120023 00100	FAF 2 RAL	Fixed rest fork for booms with customised RAL colour. For bolting to ground.
	P120023	FAF 2	Rest fork for booms. For bolting to ground.

Product

PLUS

TECHNICAL FEATURES

ACCESSORIES

DISCOVER U-LINK

	Code	Name	Description
	P120025 00100	FAF 2R RAL	Fixed rest fork for booms with customised RAL colour. For bolting to ground.
	P120026	ZFAF2	Additional anchor plates for cementing FAF2 forks to ground.
	D940007	GAM	Mobile rest leg for BGV barrier boom (not usable on BGV 30)
	D940008	GA AQ AT	Movable support leg for AQ or AT booms (on MOOVI, MICHELANGELO and GIOTTO barriers)
	D940009	GAMA AQ AT	Dampened movable support leg for AQ or AT booms (on MOOVI, MICHELANGELO and GIOTTO barriers)
	P120018	THERMO	Thermostat controlled heating element for use with MOOVI barriers - THERMO
	N190104	BIR C	Rubber safety edge (H 30 mm), price per m
	P111409	S RFLP	Reflector and support for wall mounting and mounting on CC post for CELLULA RFL
	P903015 00001	KIT BARR RFL	RFL mount. Fits onto the MICHELANGELO operator enclosure in line with the boom.
	D111904	MITTO B RCB02 R1	Transmitter with 2 channels. Range 50/100 m. Power supply 12 V with 1 battery type 23 A
	P111537	ERIS A30	Coppia di fotocellule wireless con possibilità di gestione di una costa sensibile attiva ad infrarosso o resistiva aggiungendo STR e profili BIR C o BAR C. Possibilità di orientare il fascio di 180 ° in orizzontale e di 20 ° in verticale. Portata 30 m. Alimentazione 24 V ac/dc.
	P111526	DESME A15	Pair of self-aligning photocells. Range 30 m. Power supply 24 V ac/dc.
	P111527	DESME A15 O	Pair of photocells adjustable horizontally and vertically. IR signal synchronised to prevent any risk of blinding. Range . Power supply ac/dc.
	P111528	THEA A15 O.PF	Pair of orientable photocells with integrated flashing beacon Beam can be oriented 40° horizontally and 10° vertically. Synchronised infrared signal to avoid any possibility of accidental dazzling. Range 30 m. Power supply 24 V ac/dc. For external application.
	P903018	PHP	Pair of aluminium posts for THEA/DESME series photocells Height 522 mm

new

















• Product

• PLUS

• TECHNICAL FEATURES

• **ACCESSORIES**

• DISCOVER U-LINK

	Code	Name	Description
	P903019	PHP2 	Pair of double aluminium posts for THEA/DESME series photocells. Height 522 mm
	P903023	PHP BA1	Support for mounting THEA/DESME photocells on Giotto, Moovi and Michelangelo enclosures
	P903025	PHP ADA	Pair of adapters for the installation of AKTA photocells on PHP posts
	P111401 00001	VENTIMIGLIA NS	Infrared device for BIR C or BAR C safety edges (conforms to EN 12978 Standard)
	P121023	Q.BO KEY WM AV	Vandalproof key selector with double contact, for outdoor use. Metal structure.
	P121024	Q.BO TOUCH	Wireless digital touch button panel 433Mhz rolling code.
	D110926 00001	SPIRA 2X1	Magnetic loop 2 x 1 m
	N999608	ACTR	Pack of 12 additional reflective labels (1 pack already included with each boom)
	N999471	ECOSOL PANEL	Pannello solare con potenza massima pari a 35 Wp per la ricarica del sistema ECOSOL. Massimo 3 pannelli per impianto
	D113732	ECOSOL DOUBLE	Quadro di espansione con Batterie Compresse
	D113731	ECOSOL BOX	Centrale di comando e gestione per l'alimentazione ad energia solare di impianti con tensione di alimentazione pari a 24 V. Batterie compresse.
	N999477	ECOSOL CHARGER	100-230V - 24V battery charger for rapid charging from mains for ECOSOL BOX and ECOSOL DOUBLE - ECOSOL CHARGER
	N999476	ECOSOL CABLE	20 m extension for ECOSOL CHARGER - ECOSOL CABLE
	N999473	ECOSOL POST BR	Set of stainless steel screws and brackets for installing the ECOSOL PANEL on a post of diameter 48-100mm ECOSOL POST BR
	N999475	ECOSOL SECURITY	Anti-tamper stainless steel screw fastener kit for ECOSOL PANEL and ECOSOL POST BR - ECOSOL SECURITY











· Product

· PLUS

· TECHNICAL FEATURES

· **ACCESSORIES**

· DISCOVER U-LINK

	Code	Name	Description
	P111466	B EBA IO DRIVER	INPUT/OUTPUT expansion board
	P111467	B EBA WIE DRIVER	Scheda di espansione per il collegamento di accessori WIEGAND, compatibile con centrali U-Link
	P111468	B EBA RS 485 LINK	Expansion board for connection of central units with serial controls management
	P111469	B EBA BLUE GATEWAY	Expansion board for BLUETOOTH connection management
	P111531	B EBA BLUE ENTRY ANDROID 4	BLUE-TOOTH expansion card for Blue Entry system. Manages up to 4 smartphones with the Android operating system
	P111532	B EBA BLUE ENTRY ANDROID 8	BLUE-TOOTH expansion card for Blue Entry system. Manages up to 8 smartphones with the Android operating system
	P111533	B EBA BLUE ENTRY ANDROID 16	BLUE-TOOTH expansion card for Blue Entry system. Manages up to 16 smartphones with the Android operating system
	P111530	B EBA RS 485 GATEWAY	GATEWAY expansion card for management of RS 485 connection
	D113674 00001	CLONIX 2E	CLONIX 2E 433 MHz dual channel external receiver with rolling code (to be used if there is no CLONIX receiver in the system)
	D113718 00002	CLONIX 4 RTE	External 4-channel 433 MHz rolling code receiver. Power relay outputs (16A 230v)
	D113746 00003	GSM RECEIVER	GSM receiver. Enables the operation of an automation system with a free phone call
	D113807 00002	CLONIX 2E AC U-LINK 230	 433Mhz external receiver with 2 outputs with NO contact. Compatible with U-LINK protocol (with 3 connection slots). Power supply 230V, 2048-position memory
	D113808 00003	CLONIX UNI AC U-LINK 230V	 433Mhz external receiver with 3 outputs: 2 with NO contact and one NO/NC configurable. Compatible with U-LINK protocol (with 3 connection slots). Power supply 230V, 2048-position memory

· Product

· PLUS

· TECHNICAL FEATURES

· ACCESSORIES

· DISCOVER U-LINK

What is U-Link?

The innovative technology that gives you new power

An exclusive Bft innovation: U-Link (Universal Link) is an exclusive Bft platform that allows the creation of technological ecosystems. In Home Automation Access, it allows communication with all the home access automation devices of any brand. So you save time and can control everything with ease, without any worries.

It is intuitive

Easy to install and use

It is scalable

Allows an unlimited number of devices to be added

It is flexible

Allows the creation of groups of interconnected products

It is practical

Works with or without a web connection

It is functional

Parameters can be controlled remotely via dedicated applications

- Product
- PLUS
- TECHNICAL FEATURES
- ACCESSORIES
- DISCOVER U-LINK

All in one scheme: discover this amazing technology

A unique platform **allowing the creation of technological ecosystems** offering a wide range of solutions for different sectors.

Thanks to the B-Eba cards and the Clonix U-Link receiver, this proprietary platform featured by Bft products adapts to any protocol and access automation product (even non-Bft and old generation), and is used in various sectors. Each device thus becomes smart and can be interconnected with other systems, thanks to a language that becomes universal.

U-Base 2

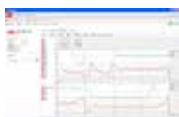

Software to install, easily and comfortably carry out maintenance and identify any malfunction of U-link compatible operators.

U-SDK



U-SDK is the innovative application that can make Bft automation systems compatible and easily integrated with a BMS network for the supervision of buildings.



Magistro

An innovative and easy to install system for easily managing all the home automation.



U-Control

U-Control is the application that helps the simple and quick integration of BFT automations in large building management systems.



Blue-Entry

Technology abreast of the times and attentive to daily needs: thanks to the use of U-link the house gate can now be opened with just your smartphone.



Clonix U-Link

Allows the connection of old-generation products or non-Bft products to U-Link systems.

Old-generation Bft operators or a product belonging to other brands: can they be connected to U-link? Yes, thanks to the Clonix receivers. Accessories that know no limits.



B-eba

A direct line with your operators.

B-eba expansion cards allow the connection of external devices, such as PCs, smartphones and tablets, to a Bft operator or Clonix receiver, or the connection of several Bft products in a U-Link network. These accessories integrate with U-Link technology and Bluetooth, Z-Wave, TCP/IP protocols, as well as the RS485 serial connection. A device that fully translates what Bft intends as interconnectivity.

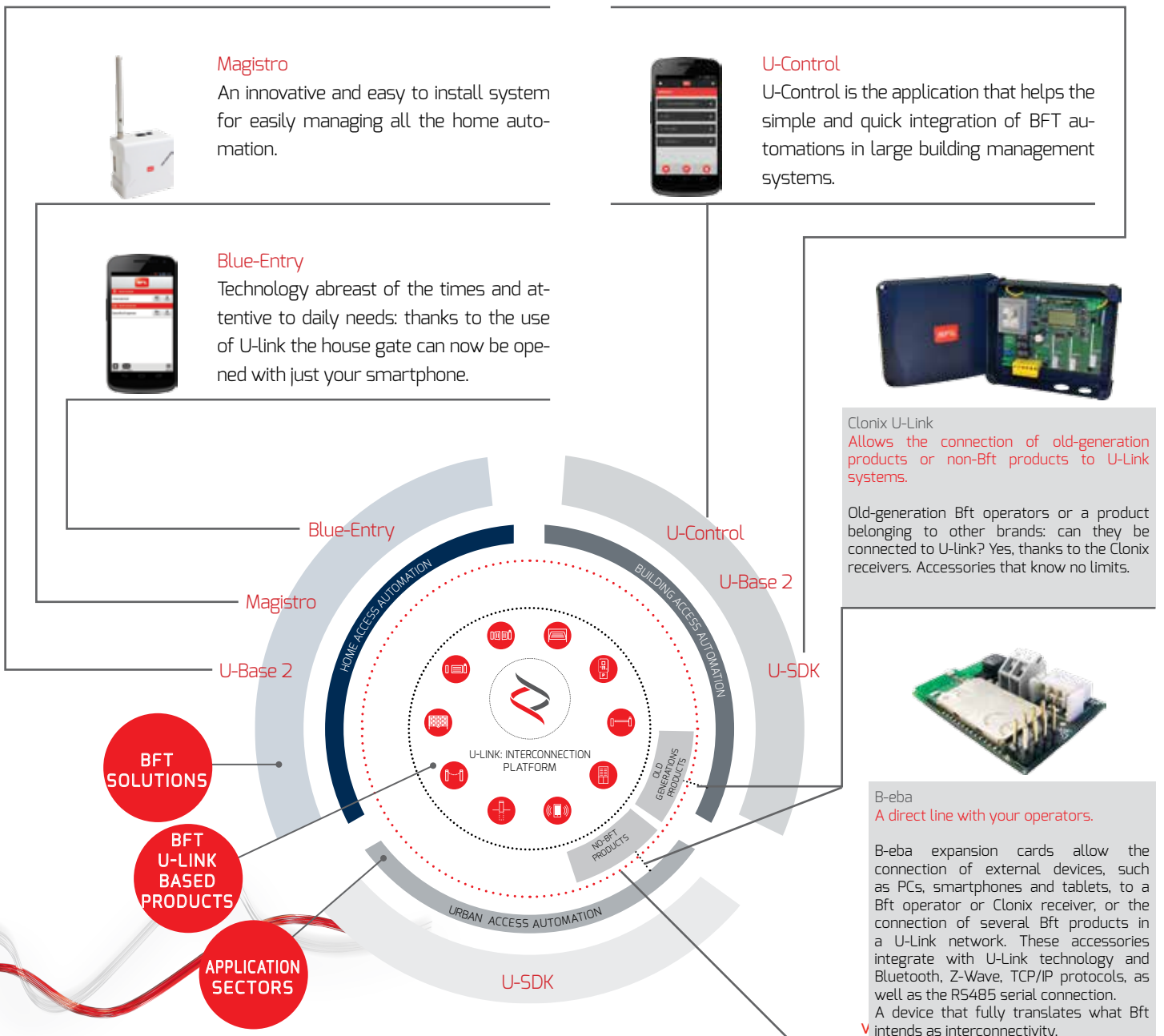



INFORMATION REGARDING THE PROTECTION OF THE INDUSTRIAL AND INTELLECTUAL PROPERTY RIGHTS OF BFT. BFT S.p.A. protects its industrial property by depositing trademarks, patents, models and designs. The intellectual property of BFT S.p.A. is protected by copyright law. BFT S.p.A. also protects its know-how by taking measures to protect the technical and commercial information inherent in its company and products. All the products in this catalogue are ORIGINAL BFT MODELS and only BFT S.p.A is authorised to produce them and market them anywhere in the world. All the commercial names in this catalogue are owned by BFT S.p.A., and only BFT S.p.A. is authorised to use them in relation to the corresponding merchandise category. FALSIFIERS WILL BE PROCEEDED AGAINST IN ACCORDANCE WITH BOTH CIVIL AND CRIMINAL LAW. THESE CONDITIONS NOT ONLY GUARANTEE THE INTELLECTUAL PROPERTY RIGHTS OF BFT, BUT ALSO PROTECT CUSTOMERS BY GUARANTEEING THAT THE PRODUCTS THEY ARE PURCHASING ARE ORIGINAL BFT PRODUCTS RESULTING FROM STUDIES AND DESIGNS WITHIN THE BFT COMPANY.