



er ready



d-track



rolling code



U-Link



ee link



Encoder



Oil Gear



230V sliding gate operators for very intensive use, extremely sturdy and high-performance thanks to oil bath transmission. Control of torque via D-track technology and absolute encoder for maximum precision of movement. Control unit arranged for communication with U-link protocol and with tamper-proof function.

The control unit ensures complete safety thanks to the exclusive torque control system that makes these operators comply fully with the current European standards.

## DIMENSION (MM)

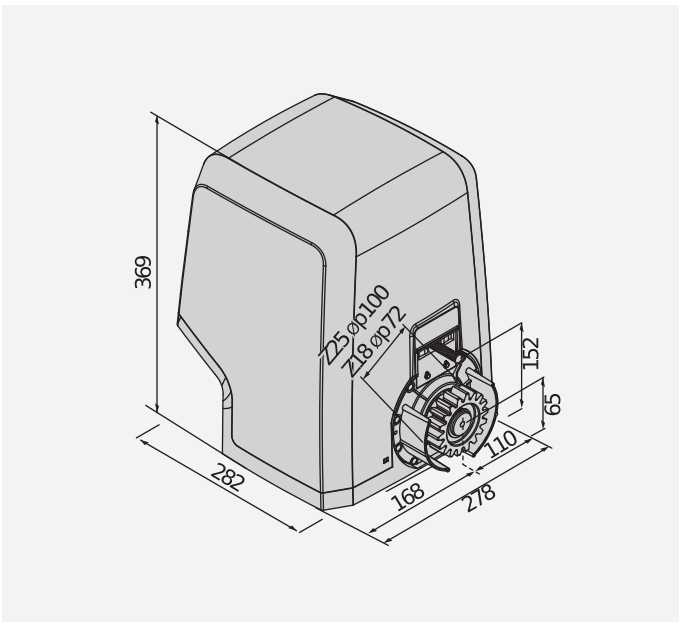

## TECHNICAL FEATURES

	ICARO ULTRA AC A2000
Control unit	
Board power supply	230 V
Supply voltage AC	230 V
Power input	750 W
Max. door/gate weight	2000 kg
Gate speed	9 m/min
Type of limit switch	Magnetic
Pinion module	4
Slowdown	Yes
Locking	Mechanical
Release	Lever-operated with personal key
Impact reaction	Mechanical clutch
Frequency of use	very intensive
Protection rating	IP55
Environmental conditions	-20 ÷ 55 °C



Code	Name	Description		
P925238 00002	ICARO ULTRA AC A2000	Operator 230 V for sliding gates up to 2000 kg with absolute encoder. Leaf speed 9 m/min. Limit switch Magnetic. Equipped with mechanical safety clutch, torque management via D-track technology and gear unit in oil bath. Control unit arranged for communication with U-link protocol and tamper-proof function. Operator with absolute encoder and torque management with D-track system.		

### LEO B CBB L02: Incorporated control unit for one 230V operator for sliding gates.

#### LEO B CBB L02 - Built-In



- Incorporated control unit for one 230V operator for sliding gates
- Application: built-in control unit for one 230V operator for sliding gates
- Board power supply: 230V single-phase
- Operator power supply: 230V 750W
- Main features: removable terminal blocks with new standard colour-coding, simplified scenario-based programming with display, incorporated dual channel receiver, D-Track anti-crushing system, slowdown during opening and closing
- Main functions: automatic re-closing, fast closing, pedestrian opening

## RECOMMENDED ACCESSORIES

	P111468 - <b>B EBA RS 485 LINK</b>		D221073 - <b>CP</b>
	Expansion board for connection of central units with serial controls management.		plastic rack, 4-module, cross-section 22 x 22 mm, length 1 m, screw-fitted into slots. Max. load capacity 600 kg.
	D571053 - <b>CVZ</b>		N999320 - <b>CVZ-S</b>
	steel rack, 4-module, cross-section 30 x 12 mm, length 1 m, vite su supporti. Max. load capacity 1000 kg.		steel rack, 4-module, cross-section 30 x 8 mm, length 1 m, screw-fitted on supports. Max. load capacity 800 kg.
	D571054 - <b>CFZ</b>		P125018 - <b>THEKE B PRA 01</b>
	galvanized steel rack, 4-module, cross-section 22 x 22 mm, length 2 m, welding. Max. load capacity 2000 kg.		Metal protection box for ARES and ICARO series sliding operators.
	N999156 - <b>SFI</b>		
	Base plate for ARES and ICARO (supplied with operator).		

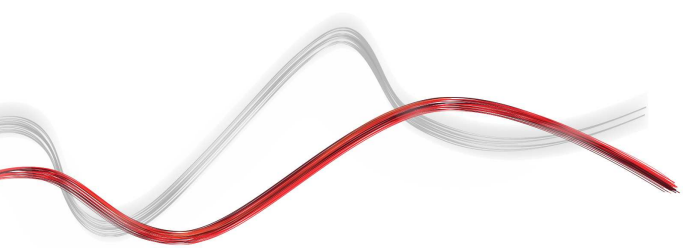

[www.bft-automation.com](http://www.bft-automation.com)

INFORMATIVA A TUTELA DEI DIRITTI DI PROPRIETA' INDUSTRIALE E INTELLETTUALE DI BFT. BFT S.p.A. tutela i propri diritti di proprietà industriale attraverso il deposito di marchi, brevetti, modelli e design. La proprietà intellettuale di BFT S.p.A. è tutelata a norma della legge sul diritto d'autore. BFT S.p.A. tutela inoltre il proprio know-how adottando misure di protezione delle informazioni tecniche e commerciali inerenti la propria azienda e i propri prodotti. Tutti i prodotti presenti in questo catalogo sono MODELLI ORIGINALI BFT e BFT S.p.A. è la sola autorizzata a produrli e commercializzarli in tutto il Mondo. Tutti i nomi commerciali attribuiti ai prodotti presenti in questo catalogo sono di titolarità di BFT S.p.A. che è la sola autorizzata al loro uso in relazione alla relativa categoria merceologica. I CONTRAFFATTORI VERRANNO PERSEGUITI A NORMA DI LEGGE SIA IN SEDE CIVILE CHE PENALE. IL TUTTO A GARANZIA NON SOLO DEL PATRIMONIO INTELLETTUALE DI BFT, MA ANCHE A TUTELA DEI CLIENTI CHE ACQUISTANDO PRODOTTI BFT ACQUISTANO PRODOTTI ORIGINALI FRUTTO DI STUDI E PROGETTI INTERNI ALLA SOCIETA' BFT.